



PERCOTRONICS®



HPI TESTER

@percotronics



www.percotronics.com

HPI TESTER



HPI Injector Test Bench — For proper operation, the bench must have a 17 mm cam travel. **CUMMINS/SCANIA**, compatible with **HARTRIDGE CAM-BOX**.

MAIN FUNCTIONS:

- Internal set of **flow and feed control valves**.
- Intuitive software with **semi-automatic testing**.
- Generates **test reports**.

SIMPLE AND DYNAMIC OPERATION:

Our equipment, together with the CAM BOX, **can perform the following tests:**

- Nozzle leakage test.
- Element pressure test.
- Return valve test.
- Injection advance and retard test.
- Delivery flow test.



HPI TESTER

INCLUDES TOOLS FOR ROTARY PUMP:

- Disassembly
- Evaluation
- Recovery
- Assembly

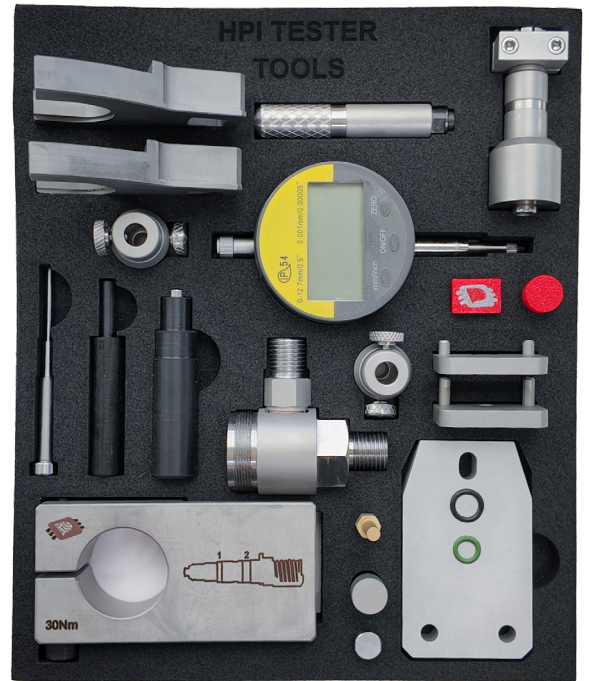

ADAPTERS FOR INJECTOR MOUNTING IN THE CAM BOX

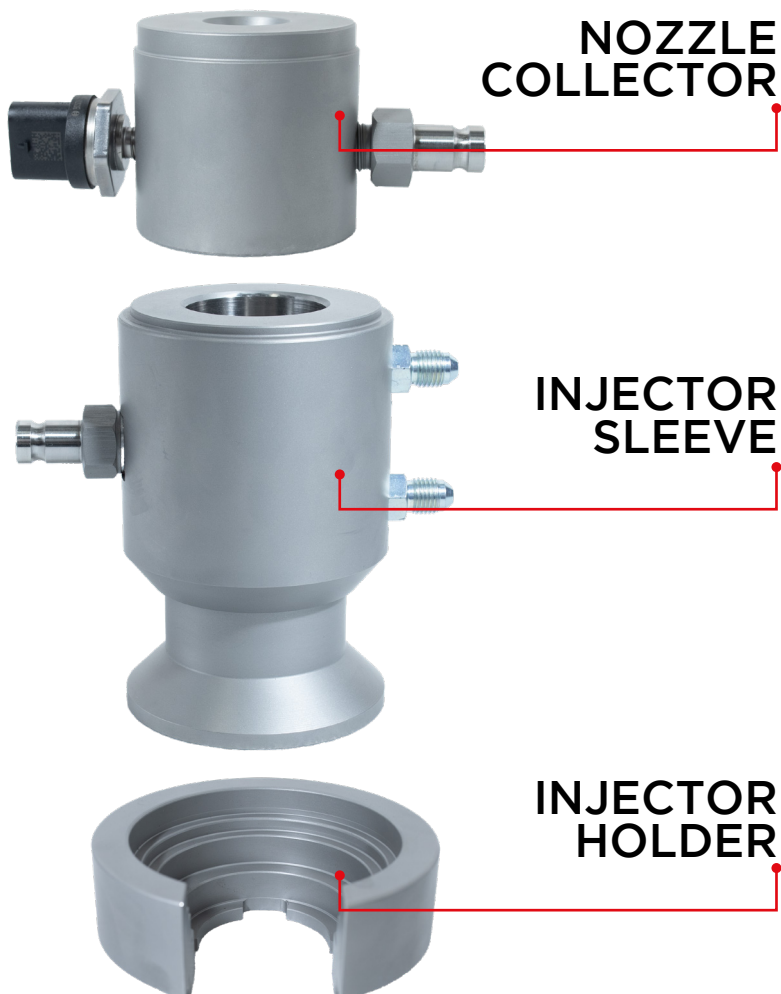

QUICK COUPLINGS X2

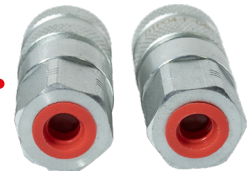

SOFTWARE HPI TESTER

CON EXPERIENCIA DE USUARIO INTUITIVA

Power Supply Voltage (Interface)

Flywheel Revolutions Per Minute (RPM) of the Test Bench

Voltaje

RPM

Presure

Temp

12,5 V

601 1/min

20,7 bar

27,3 °C

Fuel Supply Pressure

Fuel Inlet Temperature

SOFTWARE HPI TESTER

CON EXPERIENCIA DE USUARIO INTUITIVA

Purge Time

Nozzle spray pressure

Flow delivery

The screenshot displays the HPI Tester software interface with the following elements:

- Parameters:**
 - Voltaje: 12,5 V
 - RPM: 601 1/min
 - Presure: 20,7 bar
 - Temp: 27,3 °C
- Graphs:**
 - Tobera:** A graph showing a single spray pulse. Values: Tobera 47,3, Temp 54,8.
 - Avance:** A graph showing injection timing measurement. Value: Avance 7.
- Legend:**
 - LOW IDLE
 - HIGH IDLE
 - MAX POWER (checked)
 - MIDDLE POWER
 - MAX TORQUE
 - SPILL TIMING
- Data Table:**

PRUEBA				SIGUIENTE
RPM	TOBERA	cc TEORICO	cc REAL	RETORNO
400,00	21,00	60,00	70,00	0,00
400,00	22,00	110,00	95,00	0,00
900,00	90,00	242,50	240,00	100,00
900,00	80,00	200,00	180,00	130,00
600,00	50,00	195,00	170,00	120,00
600,00	50,00			
- Buttons:** DATOS CLIENTE, REPORTES, Stop

Injection timing measurement

Data Table: Parameter Display for Each Test

SOFTWARE HPI TESTER

CON EXPERIENCIA DE USUARIO INTUITIVA

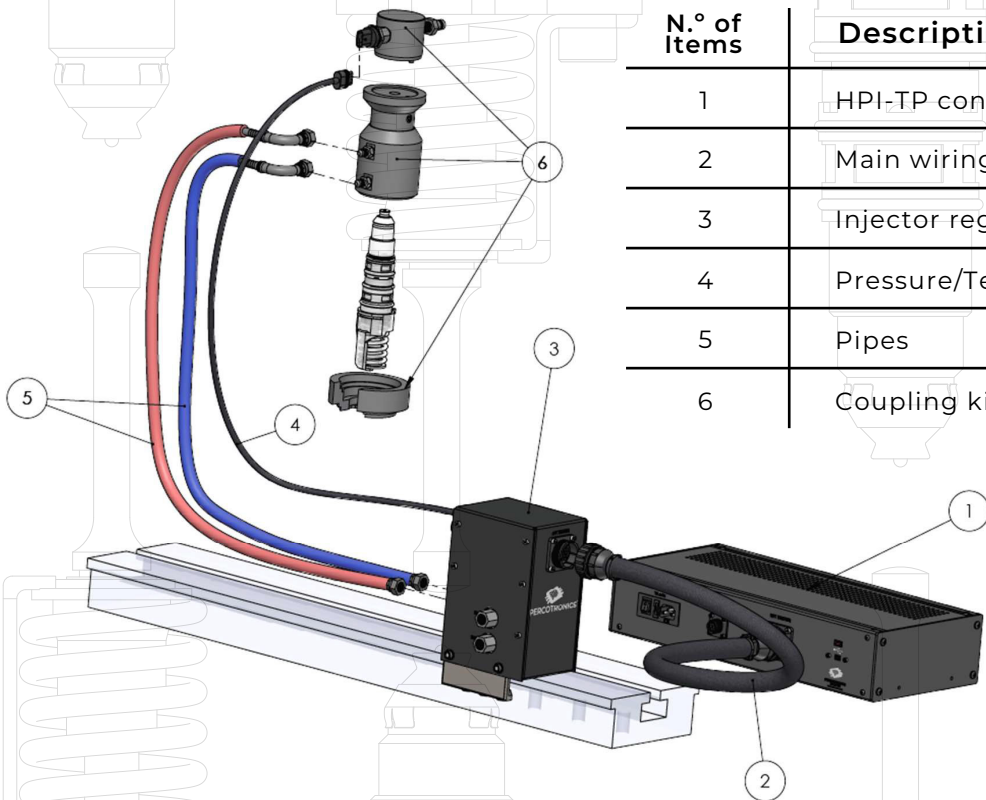

N.º of Items	Description
1	HPI-TP control module
2	Main wiring harness – HPI TESTER
3	Injector regulation assembly
4	Pressure/Temperature sensor wiring
5	Pipes
6	Coupling kit